

SPEED IS POWER

M3 MOBILE



**Product Catalogue
2020**

www.m3mobile.net

“M3 Mobile is a world-class industrial mobile computer manufacturing company that has been successful for 20 years.
We do Design, Development, Production, Sales, Maintenance directly.”

Sung-Jea, Cho
President & CEO, M3 Mobile Co., Ltd.

Corporate History

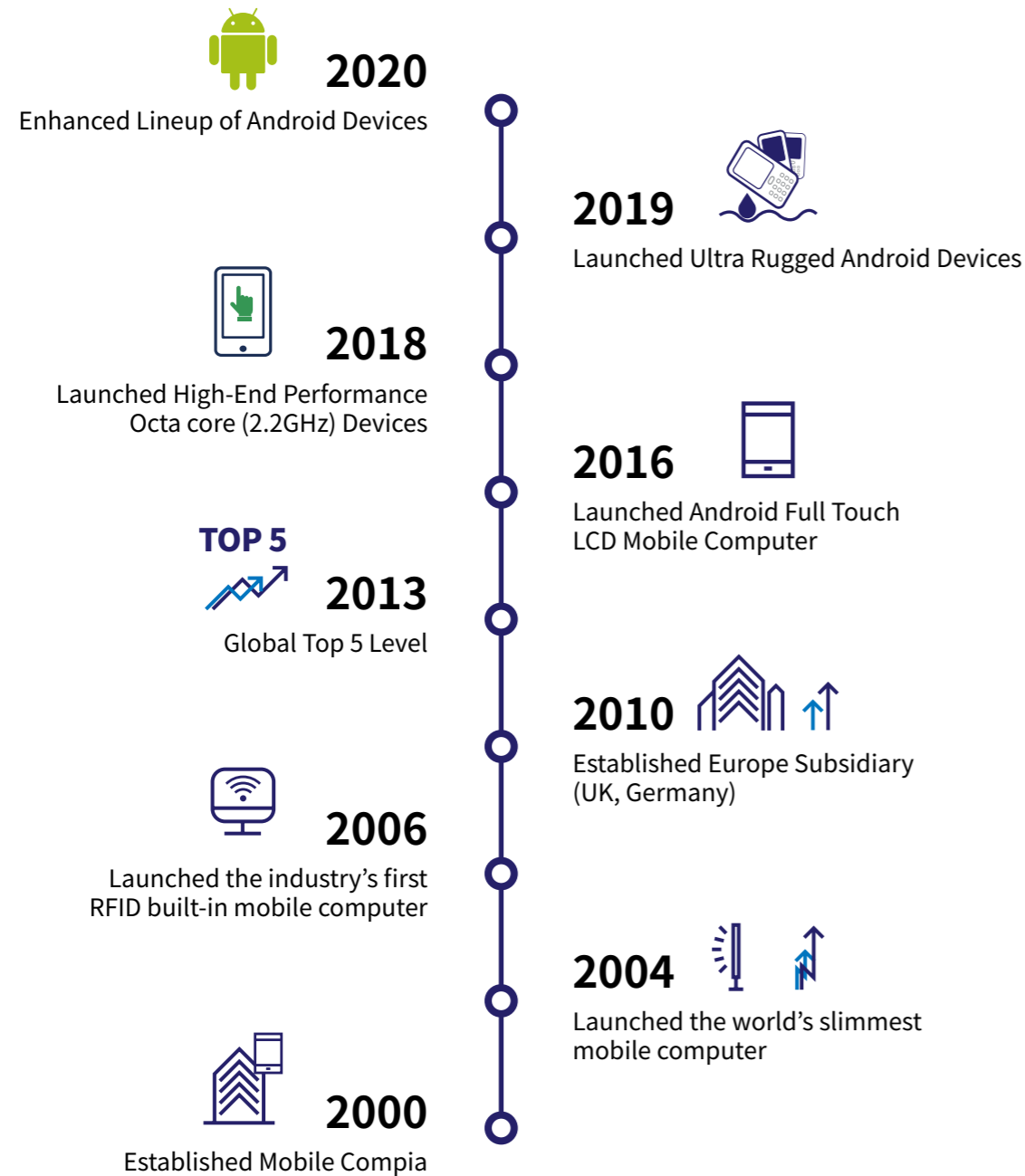

Global Office



Application Area





SPEED IS POWER

Product Line-Up

UL20X, UL20F, UL20W
SM15X, SM15N, SM15W
SM15 Accessory
SL10 Series
BK10 (BLACK)
OX10-1G (ORANGE)

PRODUCT LINE UP

		UL20X	UL20F	UL20W	SL10-N / W	SL10K-N / W	SM15X	SM15N	SM15W	BK10	OX10-1G
Performance Characteristics	CPU	2.2 GHz Octa core	2.2 GHz Octa core	2.0 GHz Octa core	1.44 GHz Quad-core processor	1.44 GHz Quad-core processor	2.2GHz Octa Core	2.0GHz Octa Core	2.0GHz Octa Core	1GHz	1GHz
	Operating System	Android 8.1 & 9.0 GMS	Android 9.0 GMS	Android 8.1 & 9.0 GMS	SL10-N : Android 8.1 GMS SL10-W : Android 8.1	Android 8.1	Android 7.1 & 8.1 GMS	Android 7.1 & 8.1 GMS	Android 7.1 & 8.1	Windows Embedded Handheld 6.5 Windows CE 6.0	Windows Embedded Handheld 6.5 Windows CE 6.0
Physical Characteristics	Memory (RAM/ROM)	4 GB / 32 GB	4 GB / 32 GB	2 GB / 16 GB	2 GB / 16 GB	2 GB / 16 GB	4GB / 32GB	2GB / 16GB	2GB / 16GB	512 MB / 8GB	512MB / 4GB
	Dimension (LxWxD)	88.7 x 244.75 x 46.19 mm	88.7 x 244.75 x 46.19 mm	88.7 x 244.75 x 46.19 mm	156 x 74 x 17mm	155.8 x 72 x 25 mm	154.8 x 76.4 x 21.6mm	154.8 x 76.4 x 21.6mm	154.8 x 76.4 x 21.6mm	75.3 x 165.8 x 26 mm	78.6 x 165.5 x 24.9 mm 78.6 x 165.5 x 40.2mm (with HF) 78.6 x 165.5 x 38.9mm (with UHF)
	Weight	530g (2D Scanner), 580g (Long-range Scanner)	530g (2D Scanner), 580g (Long-range Scanner)	530g (2D Scanner), 580g (Long-range Scanner)	260 g	292 g	280g / 9.8 oz. (incl. Standard BAT) 310g / 10.9 oz. (incl. Extended BAT)	280g / 9.8 oz. (incl. Standard BAT) 310g / 10.9 oz. (incl. Extended BAT)	280g / 9.8 oz. (incl. Standard BAT) 310g / 10.9 oz. (incl. Extended BAT)	322g / 11.7 oz. (incl. Standard BAT) 336g / 11.8 oz. (incl. Extended BAT)	332g / 11.7oz. ,362g / 12.7oz. (with HF) 389g / 13.7oz. (with UHF)*
	Display	5-inch FHD (1920 x 1080)	5-inch FHD (1920 x 1080)	5-inch FHD (1920 x 1080)	5-inch HD (1280 x 720)	4 in. WVGA (800 x 480)	5-inch FHD (1920 x 1080)	5-inch HD (1280 x 720)	5-inch HD (1280 x 720)	3.5-inch VGA (480 x 640) QVGA (240 x 320)	3.5-inch VGA (480 x 640) QVGA (240 x 320)
	Touchpanel	Corning Gorilla Glass 3 / Capacitive multi-touch / Glove, Wet, Stylus	Corning Gorilla Glass 3 / Capacitive multi-touch / Glove, Wet, Stylus	Corning Gorilla Glass 3 / Capacitive multi-touch / Glove, Wet, Stylus	Capacitive touch	Capacitive touch	Corning Gorilla Glass 3 Capacitive multi-touch / Glove, Wet, Stylus	Corning Gorilla Glass 3 Capacitive multi-touch / Glove, Wet, Stylus	Corning Gorilla Glass 3 Capacitive multi-touch / Glove, Wet, Stylus	Resistive touch	Resistive touch
	Power (Battery)	Li-ion 3.6 V / 6,700 mAh	Li-ion 3.6 V / 6,700 mAh *Designed for high-performance in low temperatures*	Li-ion 3.6 V / 6,700 mAh	Li-ion 3.8 V / 4,000 mAh	Li-ion 3.8V 4,400mAh	Li-Ion 3.8V/4,100mAh Li-Ion 3.8V,6,150mAh	Li-Ion 3.8V/4,100mAh Li-Ion 3.8V,6,150mAh	Li-Ion 3.8V/4,100mAh Li-Ion 3.8V,6,150mAh	Li-Polymer 3.7V,3,400mAh Li-Polymer 3.7V,5,100mAh	Li-Ion 3.7V,3,300mAh N/A
	Hot Swap	O	O	O	X	X	O	O	O	O	O
	Expansion Slot	Micro SD	Micro SD	Micro SD	Micro SD (up to 128GB)	Micro SD (up to 128GB)	Micro SD	Micro SD	Micro SD	Micro SD	Micro SD
	SIM / SAM	2 SIM	N / A	N / A	1 SIM (SL10-N only)	1 SIM	2 SIM or 1 SIM/1SAM	2 SIM or 1 SIM/1SAM	N/A	1 SIM	1 SIM / 2SAM
	Keypad	35 Key Alpha Numeric Function Keypad, 6 Side Key (28, 53 Key available)	35 Key Alpha Numeric Function Keypad, 6 Side Key (28, 53 Key available)	35 Key Alpha Numeric Function Keypad, 6 Side Key (28, 53 Key available)	4 physical keys + 2 side scan + volume	17 physical keys + 2 side scan + volume	4 Front Key 5 Side Key	4 Front Key 5 Side Key	4 Front Key 5 Side Key	34 Key Alpha Numeric, 5 Side Key 53 Key Qwerty, 5 Side Key	31 Key Alpha Numeric, 4 Side Key 50 Key Qwerty, 4 Side Key
Side Key	Volume / Scan / Scroll	Volume / Scan / Scroll	Volume / Scan / Scroll	Volume / Scan	Volume / Scan	VOLUME / SCAN / CAM	VOLUME / SCAN / CAM	VOLUME / SCAN / CAM	VOLUME / SCAN / CAM	VOLUME / SCAN / CAM	
Wireless WAN Data and Voice Communications	Radio Frequency Band	LTE / UMTS / HSPA+ / GSM / GPRS / EDGE	N / A	N / A	LTE / WCDMA / TD-SCDMA / GSM (SL10-N only)	LTE / WCDMA / TD-SCDMA / GSM (SL10K-N only)	LTE / UMTS/HSPA+ / GSM/GPRS/EDGE	LTE / UMTS/HSPA+ / GSM/GPRS/EDGE	N/A	UMTS/HSPA+ GSM/GPRS/EDGE	UMTS/HSPA+ GSM/GPRS/EDGE
	GPS	GPS, A-GPS, GLONASS, BEIDOU	N / A	GPS, A-GPS, GLONASS, BEIDOU	GPS with A-GPS (Glonass, BeiDou) (SL10-N only)	GPS with A-GPS (Glonass, BeiDou) (SL10K-N only)	GPS, A-GPS, GLONASS, BEIDOU	GPS, A-GPS, GLONASS, BEIDOU	N/A	AGPS, GLONASS	AGPS, GLONASS
Wireless LAN	Radio	802.11 a / b / g / n / ac	802.11 a / b / g / n / ac	802.11 a / b / g / n / ac	IEEE 802.11 a/b/g/n, Frequency 2.4G+5.8G dual band WIFI	IEEE 802.11 a/b/g/n, Frequency 2.4G+5.8G dual band WIFI	802.11 a/b/g/n/ac	802.11 a/b/g/n/ac	802.11 a/b/g/n	802.11 a/b/g/n	
Wireless PAN	Bluetooth	Class II 4.1 LE	Class II 4.1 LE	Class II 4.1 LE	Class I 4.0 LE	Class I 4.0 LE	Class II V4.1 LE	Class II V4.1 LE	Class II V4.1 LE	Class II v2.1 with EDR	Class II v2.1 with EDR
Wired LAN	Ethernet	O	O	O	X	X	O	O	O	O	
Data Capture	Scanning	2D Imager, Long-range Scanner (SE4850)	2D Imager, Long-range Scanner (SE4850)	2D Imager, Long-range Scanner (SE4850)	1D / 2D	1D / 2D	1D / 2D, Long-range(optional)	1D / 2D, Long-range(optional)	1D / 2D, Long-range(optional)	1D/2D	1D/2D
	Camera	Rear - 16.0MP Auto Focus	Rear - 16.0MP Auto Focus	Rear - 16.0MP Auto Focus	8.0 M(Rear), 2.0 M(Front)	8.0 M(Rear), 2.0 M(Front)	Front - 5MP Auto Focus Rear - 16MP Auto Focus	Front - N/A Rear - 13MP Auto Focus	Front - N/A Rear - 13MP Auto Focus	Rear - 5.0 MP Auto focus	Rear - 5.0 MP Auto Focus
	RFID	NFC (13.56MHz) Peer-to-peer, card reader, card emulation ISO 14443 A / B, ISO 15693	NFC (13.56MHz) Peer-to-peer, card reader, card emulation ISO 14443 A / B, ISO 15693	NFC (13.56MHz) Peer-to-peer, card reader, card emulation ISO 14443 A / B, ISO 15693	NFC	NFC	NFC	NFC	NFC	NFC	N/A
User Environment	Operating Temp.	-20 °C to 60 °C (-4 °F to 140 °F)	-20 °C to 60 °C (-22 °F to 140 °F)	-20 °C to 60 °C (-4 °F to 140 °F)	-20 °C to 50 °C (-4 °F to 122 °F)	-20 °C to 50 °C (-4 °F to 122 °F)	-20 to 60°C / -4 to 140°F	-20 to 60°C / -4 to 140°F	-20 to 60°C / -4 to 140°F	-20 to 60°C / -4 to 140°F	-20 to 60 °C / -4 to 140 °F
	Storage Temp.	-30 °C to 80 °C (-22 °F to 176 °F)	-40 °C to 80 °C (-40 °F to 176 °F)	-30 °C to 80 °C (-22 °F to 176 °F)	-30 °C to 70 °C (-22 °F to 158 °F)	-30 °C to 70 °C (-22 °F to 158 °F)	-30 to 80°C / -22 to 176°F	-30 to 80°C / -22 to 176°F	-30 to 80°C / -22 to 176°F	-30 to 80°C / -22 to 176°F	-30 to 80°C / -22 to 176°F
	Humidity	95 % non-condensing	Condensing (condensation-free using internal heaters)	95 % non-condensing	0% to 95% non-condensing	0% to 95% non-condensing	0% to 95% non-condensing	0% to 95% non-condensing	0% to 95% non-condensing	95 % non-condensing	93% non-condensing
	Drop Spec.	2.0 m	2.0 m	2.0 m	1.2 m / 1.5m (with Boots)	1.2 m / 1.5m (with Boots)	1.2 m / 1.8m (with Boots)	1.2 m / 1.8m (with Boots)	1.2 m / 1.8m (with Boots)	2 m / 6.6ft	1.5 m / 5ft
	Tumble Spec.	2,000 3.2ft/1.0m tumbles(4,000 Drops)	2,000 3.2ft/1.0m tumbles(4,000 Drops)	2,000 3.2ft/1.0m tumbles(4,000 Drops)	N / A	N / A	500 1.6ft/0.5m tumbles (1,000 drops) 1,000 1.6ft/0.5m tumbles (2,000 drops) (with protective boots)	500 1.6ft/0.5m tumbles (1,000 drops) 1,000 1.6ft/0.5m tumbles (2,000 drops) (with protective boots)	500 1.6ft/0.5m tumbles (1,000 drops) 1,000 1.6ft/0.5m tumbles (2,000 drops) (with protective boots)	2,000 1.6ft/0.5m tumbles (4,000 drops)	1,000 1.6ft/0.5m tumbles (2,000 drops)
Payment	Sealing	IP67	IP67	IP67	IP65	IP65	IP65	IP65	IP65	IP65	
	MSR	N / A	N / A	N / A	N / A	N / A	N/A	N/A	N/A	N/A	
	Contact	N / A	N / A	N / A	N / A	N / A	N/A	N/A	N/A	N/A	
	Contactless	N / A	N / A	N / A	N / A	N / A	N/A	N/A	N/A	N/A	
Printer	Security	N / A	N / A	N / A	N / A	N / A	N/A	N/A	N/A	N/A	
	Speed	N / A	N / A	N / A	N / A	N / A	N/A	N/A	N/A	N/A	
	Size	N / A	N / A	N / A	N / A	N / A	N/A	N/A	N/A	N/A	
Accessories	Power Supply, USB Cable, Stylus Pen, Screen Protector, Standard Battery, 2 Slot Cradle, 8 Slot Cradle, Trigger Handle, Snap On, Keypad (These accessories are subject to change upon development plan.)	Power Supply, USB Cable, Stylus Pen, Screen Protector, Standard Battery, 2 Slot Cradle, 8 Slot Cradle, Trigger Handle, Snap On, Keypad (These accessories are subject to change upon development plan.)	Power Supply, USB Cable, Stylus Pen, Screen Protector, Standard Battery, 2 Slot Cradle, 8 Slot Cradle, Trigger Handle, Snap On, Keypad (These accessories are subject to change upon development plan.)	Power Supply, USB Cable, Standard Battery, 2 Slot Cradle, 8 Slot Cradle, Pistol Grip	Power Supply, USB Cable, Standard Battery, 2 Slot Cradle, 8 Slot Cradle, Pistol Grip	Power Supply, USB Cable, Standard Battery, 2 Slot Cradle, 8 Slot Cradle, Pistol Grip	Power Supply, USB Cable, Stylus pen, Vehicle cradle, Protective Boot, Screen Protector, Standard Battery, Extended Battery, NFC Battery cover, 2 Slot Cradle, 8 Slot Cradle, 2 Slot Ethernet Cradle, 2 Slot HDMI Cradle, 8Slot Ethernet Cradle, Scanning Trigger, UHF Gun Reader, UHF Snap On, USB Charging Snap On	Power Supply, USB Cable, Stylus pen, Vehicle cradle, Protective Boot, Screen Protector, Standard Battery, Extended Battery, NFC Battery cover, 2 Slot Cradle, 8 Slot Cradle, 2 Slot Ethernet Cradle, 2 Slot HDMI Cradle, 8Slot Ethernet Cradle, Scanning Trigger, UHF Gun Reader, UHF Snap On, USB Charging Snap On	Power Supply, USB Cable, Stylus pen, Vehicle cradle, Protective Boot, Screen Protector, Standard Battery, Extended Battery, NFC Battery cover, 2 Slot Cradle, 8 Slot Cradle, 2 Slot Ethernet Cradle, 2 Slot HDMI Cradle, 8Slot Ethernet Cradle, Scanning Trigger, UHF Gun Reader, UHF Snap On, USB Charging Snap On	Power Supply, USB Cable, Stylus pen, Vehicle cradle, Fabric case, Leather case, Screen Protector, Standard Battery, Extended Battery, 2 Slot Cradle, 8Slot Cradle, 2 Slot Ethernet Cradle, 8Slot Ethernet Cradle, Scanning Trigger	Power Supply, USB Cable, Stylus pen, Vehicle cradle, Screen Protector, Standard Battery, 2 Slot Cradle, 8Slot Cradle, Scanning Trigger, UHF Gun Reader

SPEED IS POWER
M3



M3 UL20 Series

Full Touch Ultra-Rugged Computer

Android 8.1 & 9.0 GMS
2.2GHz Octa core CPU
Fast charging / Battery Hot Swap
1D / 2D Imager, Long-range Scanner
16.0MP Auto Focus Camera



Full HD Display

With large, high-resolution colour screen for clear visibility both indoor and outdoor.



Keypad (35 keys + Function keys)

For maximum efficiency, physical keyboards are available. M3 UL20 includes 35-key alpha numeric keypad. All features in easy-to-use ergonomic design and function keys are installed for fast operation in the field.



IP67 sealing, 2.0m drop

IP67 dust / water proof and withstands 2.0m drops. The device can be used in harsh environments.



Li-ion, 3.6V, 6,700mAh

The large capacity 6,700mAh battery makes it suitable for long shifts in a place where battery charging is limited.

Specification

	UL20X	UL20W	UL20F
DIMENSION (W x H x D)	88.7 mm x 244.75 mm x 46.19 mm		
WEIGHT	530g (2D Scanner), 580g (Long-range Scanner)		
DISPLAY	5-inch FHD (Full High Definition) (1920X1080) Outdoor view-able, Frost-free (UL20F)		
TOUCH	Corning Gorilla Glass / Capacitive multi-touch / Glove, Wet, Stylus		
BATTERY	Li-ion 3.6 V 6,700 mAh, designed for high-performance in low temperatures (UL20F)		
POWER MANAGEMENT	Fast Charging / Battery Hot Swap		
SIM / SAM	2SIM	N/A	
PHYSICAL KEYS	35-Key Alpha Numeric+Function key pad and 6 Side key, (Optional) 28-Key, 53-Key		
PROCESSOR	2.2 GHz Octa-core processor	2.0 GHz Octa-core processor	2.2 GHz Octa-core processor
OS	Android 8.1 & 9.0 GMS		
MEMORY	4GB RAM, 32GB ROM	2GB RAM, 16GB ROM	4GB RAM, 32GB ROM
INTERFACE	USB 2.0 Client (C type), USB 2.0 Host (A type)		
SENSOR	Accelerometer, Gyro, Ambient light, Proximity, E-compass, Magnetic		
WWAN	GSM : B3, B5, B8 WCDMA : B1, B5, B8 TDD-LTE : B38, B40, B41 FDD-LTE : B1, B3, B5, B7, B8, B20	N/A	
WLAN	IEEE 802.11 a / b / g / n / ac 2.4 & 5 GHz		
BLUETOOTH	Bluetooth v4.1 LE Class II		
GPS	A-GPS, GLONASS, Beidou, Galileo	N/A	
SCANNER	2D Imager Long-range (SE4850)		
CAMERA	16.0 MP (REAR) LED Flash		
RFID	NFC (13.56MHz) Peer-to-peer, card reader, card emulation ISO 14443 A / B, ISO 15693		
TEMPERATURE	Operating -20 °C to 60 °C (-4 °F to 140 °F) Storage -30 °C to 80 °C (-22 °F to 176 °F)		Operating -30 °C to 60 °C (-22 °F to 140 °F) Storage -40 °C to 80 °C (-40 °F to 176 °F)
HUMIDITY	0% to 95% non-condensing		Condensing (Condensation-free using internal heaters)
DROP TEST	2.0M		
IP RATING	IP67		
HEATER	N/A		Scanning window heater, LCD Heater



M3 UL20F

High-Performance in cold environments



Defogging keeps screen clear

UL20 has a sensor and smart module to keep the screen and scanner window at an optimum temperature so they can stay clear, even in cold environments. The screen heater continues to operate when the UL20 is in sleep mode. The battery also resists low temperature.



UL20F Scanning Window

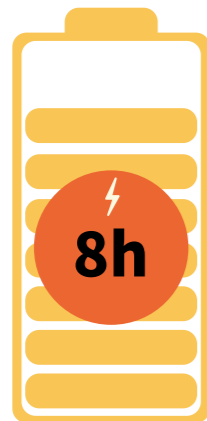
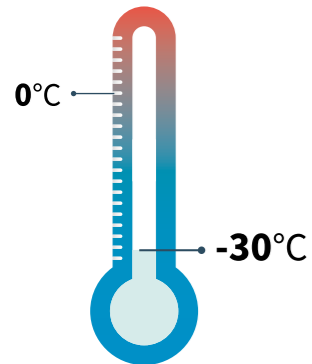

Resists low temperature! (It applies to UL20F)

In cold warehouse, it is essential that LCD and keypad work normally in low temperature. UL20F is upgraded to work at -30°C by automatically controlling LCD heating. It provides convenience to the user as well as reducing battery consumption.

Furthermore, the special freezer battery maintains performance in extreme cold.

M3 UL20W

Support WiFi-Only Products

UL20W is specialized for indoor working space where Wi-Fi is usually used. This reasonable product, UL20W will reduce your TCO (Total cost of ownership). Smooth indoor operation has a benefit in free compatibility with many kinds of apps. Data communication between co-workers becomes stable if they're connected with Wi-Fi. Wireless communication becomes fast and stable just like wired one.



M3 UL20 Series Accessory



2 slot Charging Cradle
Charging & Ethernet function



8 slot Charging Cradle
Charging & Ethernet function



Trigger Handle
Scanning Pistol Grip



Vehicle Cradle



Wire Plate

※ Content subject to change or added



1 **5-inch large screen**
Control the touch screen easily



2 **Long-Range Scanner**
Able to read from 20-meter distance



3 **Angled Scanner (25 degrees)**
Helps convenient aiming



M3 SM15 Series

Rugged Mobile Computer with Full Touch Screen

Android 7.1 and 8.1 GMS
2.2GHz Octa core CPU
Fast charging / Battery Hot Swap
1D Laser, 2D Imager
16.0MP Auto Focus Camera
5-inch FHD LCD (1920 x 1080)



Specification

	SM15X	SM15N	SM15W
DIMENSION (W x H x D)	76.4 x 154.8 x 21.6 mm (3.00 x 6.09 x 0.85 in)		
WEIGHT	Standard: 280 g (9.8 oz), Extended: 340 g		
DISPLAY	5-inch FHD (1920 x 1080) Outdoor viewable	5-inch HD TFT LCD (1280 x 720) Outdoor viewable	
TOUCH	Capacitive touch, Glove / Wet / Pen		
BATTERY	Standard: Li-ion 3.8V 4,100mAh, Extended: Li-ion 3.8V 6,150mAh		
POWER MANAGEMENT	Fast Charging / Battery Hot Swap		
SIM / SAM	2 SIM or 1 SIM / 1 SAM		
PHYSICAL KEYS	Volume + / - key, Camera key, Power key 2 Scanner keys (Left, Right), 4 Bottom keys (Home, Back, Menu, Enter (Scan))		
PROCESSOR	2.2 GHz Octa-core processor	2.0 GHz Octa-core processor	
OS	Android 7.1 and 8.1 GMS		
MEMORY	4 GB RAM, 32 GB ROM	2 GB RAM, 16 GB ROM	
INTERFACE	Docking connector: Micro USB (When using USB-equipped Snap-On or Cradle)		
SENSORS	Gyro Sensor / Proximity Sensor / Light Sensor		
WWAN	2G GSM / GPRS / EDGE (850 / 900 / 1800 MHz) 3.8G UMTS / HSPA+ (850 / 900 / 2100 MHz) 4G FDD LTE (800 / 850 / 900 / 1800 / 2100 / 2600 MHz)	N/A	
WLAN	IEEE 802.11 a / b / g / n / ac		
BLUETOOTH	Bluetooth Class II 4.1 LE		
GPS	A-GPS, GLONASS, BEIDOU	N/A	
SCANNER	1D Laser, 2D Imager		
CAMERA	Front: 5.0 MP Auto Focus Rear: 16.0 MP Auto Focus	Rear: 13.0 MP Auto Focus	
RFID	HF (NFC ISO 14443 A / B, ISO 15693), UHF (EPC C1 Gen2, ISO 18000 6C via Snap on / Gun reader)		
TEMPERATURE	Operating: -20°C to 60°C (-4°F to 140°F) / Storage: -30°C to 80°C (-30°F to 176°F)		
HUMIDITY	0% to 95% non-condensing		
DROP TEST	1.2M / 1.8M (with Boots)		
ESD TEST	±15 kV air Discharge and ±8 kV Direct Discharge		
TUMBLE	0.5M/1000 Cycle, 1M/500 Cycle (with Boots)		
VIBRATION	4Gs Peak Sine (5Hz to 2KHz); 0.04g~2/Hz Random (20Hz to 2kHz); 1h duration per axis, 3axis		
IP RATING	IP65		

Key points

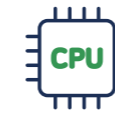

Unrivalled CPU performance
SM15X has 2.2 GHz 8 core AP which is 46% faster than other processors.



FHD (Full High Definition Display), High Sensitivity Touch
High capacity processing improves your business reliability. SM15 has a high sensitivity touch panel which enables usability with gloves and even in wet condition.



Fast Charging and High Capacity Battery
SM15 has a fast charging function. Full charging time is only 3 hours.

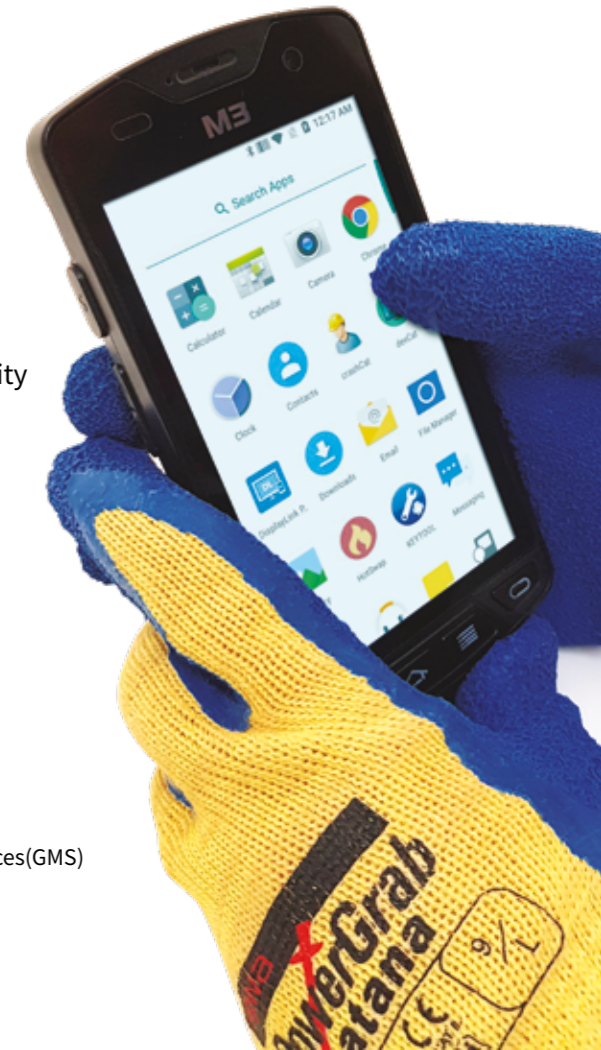

Certifications



Applications



Key Features

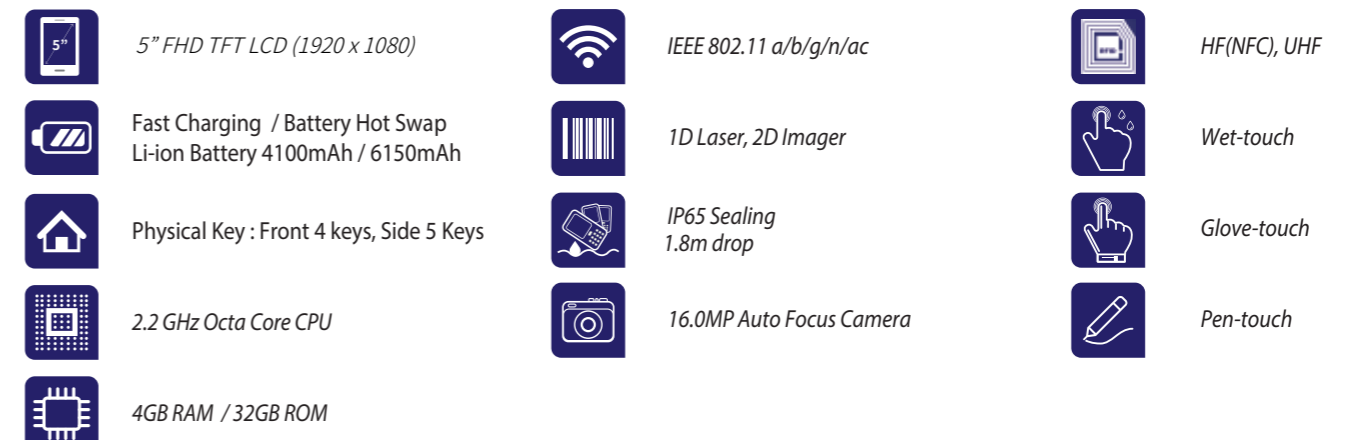

M3 SM15 Series Accessory

Charging & Data Communication



2 slot Charging Cradle
Charging-only 2 slot cradle



8 slot Charging Cradle
Charging-only 8 slot cradle



Vehicle Cradle
Charging-only vehicle cradle



2 slot Ethernet Cradle
Charging and Ethernet function included 2 slot cradle



8 slot Ethernet Cradle
Charging and Ethernet function included 8 slot cradle



HDMI Cradle
Screen mirroring between PC and SM15



USB Gender
USB Gender for Charging-only



USB Charging Snap-On (bottom)
Office, Vehicle, with captive USB charging cable



USB C-type Snap-On
USB Type Charging & Data communication



USB Charging Snap-On
USB / DC Type Charging & Data communication



UHF Snap-On
UHF RFID Snap-On

Trigger Handle



Contact with I/O Pin directly without wireless connection



Trigger Handle
Scanning Pistol Grip



UHF Gun Reader
UHF RFID & Scanning Pistol Grip

Long-Range Trigger Handle
Long-range Scanning Pistol Grip

Wearable

※ Content subject to change or added



General Purpose Headset
HD Voice, Noise Cancelling connection to wearable sled USB C-type port



Rugged Type Headset



Wearable Ring Scanner
SM15 Wearable ring scanner BT type (Charging cradle separated)



Ring Scanner Charging Cradle
(Battery charging available)
* Compatible with Android devices



Wearable wrist-mount
SM15 sled on the arm



Wearable Sled Belt
SM15 sled on the waist



Wearable Ring Trigger
SM15 Wearable trigger with QD connection cable



M3 SL10 / SL10K Series



SL10

Cost-Effective Compact Mobile Computer

Android 8.1 & GMS (SL10-N)
1.44 GHz Quad-core CPU
1D Laser, 2D Imager
8.0MP Auto Focus Camera

Accessory

※ Content subject to change or added



Trigger Handle



Charging Cradle

Certifications



Specification

	SL10-N	SL10-W
DIMENSION (W x H x D)	156 x 74 x 17mm	
WEIGHT	260 g	
DISPLAY	5.0 in. HD	
TOUCH	Capacitive touch	
BATTERY	Li-ion 3.8 V 4,000 mA	
SIM / SAM	1 SIM	
PHYSICAL KEYS	4 physical keys + 2 side scan + volume	
PROCESSOR	1.44 GHz Quad-core processor	
OS	Android 8.1 (GMS only SL10-N)	
MEMORY	RAM 2G / ROM 16G	
INTERFACE	Micro USB	
WWAN	CMCC 5M: LTE 1 / 2 / 3 / 4 / 7 / 17 / 20 / 38 / 39 / 40 / 41 WCDMA 1 / 2 / 5 / 8 TD-SCDMA 34 / 39 GSM 2 / 3 / 5 / 8	Not Applicable
WLAN	IEEE 802.11 a/b/g/n, Frequency 2.4G+5.8G dual band WIFI	
BLUETOOTH	Bluetooth Class I 4.0 LE	
GPS	GPS with A-GPS (Glonass, BeiDou)	Not Applicable
SCANNER	1D Laser, 2D Imager (SE4710)	
CAMERA	8.0 M (Rear), 2.0 m (Front), LED Flash	
RFID	NFC (13.56MHz) Peer-to-peer, card reader, card emulation ISO 14443 A / B, ISO 15693	
TEMPERATURE	Operating -20°C to 50°C Storage -30°C to 70°C	
HUMIDITY	0% to 95% non-condensing	
DROP TEST	1.2 m / 1.5m (with Boots)	
IP RATING	IP65	



SL10 K

4-inch Full Touch HD



Pocketable Android for professionals

Balanced construction is perfectly weighted for comfort, practicality and natural task support. Similar to consumer android phone, SL10 Series are sure to be satisfying end-users. Slim and light weight reduces tiredness of workers.

Real-world practicality

Processor at 1.5 GHz delivers industry-leading performance and efficiency. 5.0" HD color displays deliver sharpness and clarity for improved visibility-available in two options: high impact or high visibility.

Specification

	SL10K-N	SL10K-W
DIMENSION (W x H x D)	155.8 x 72 x 25 mm	
WEIGHT	292 g	
DISPLAY	4 in. WVGA	
TOUCH	Capacitive touch	
BATTERY	Li-ion 3.8 V 4,400 mA	
SIM / SAM	1 SIM	
PHYSICAL KEYS	17 physical keys + 2 side scan + volume	
PROCESSOR	1.44 GHz Quad-core processor	
OS	Android 8.1	
MEMORY	RAM 2G / ROM 16G	
INTERFACE	Micro USB	
WWAN	CMCC 5M: LTE 1 / 2 / 3 / 4 / 7 / 17 / 20 / 38 / 39 / 40 / 41 WCDMA 1 / 2 / 5 / 8 TD-SCDMA 34 / 39 GSM 2 / 3 / 5 / 8	Not Applicable
WLAN	IEEE 802.11 a/b/g/n, Frequency 2.4G+5.8G dual band WIFI	
BLUETOOTH	Bluetooth Class I 4.0 LE	
GPS	GPS with A-GPS (Glonass, BeiDou)	Not Applicable
SCANNER	1D Laser, 2D Imager (SE4710)	
CAMERA	8.0 M (Rear), 2.0 m (Front), LED Flash	
RFID	NFC (13.56MHz) Peer-to-peer, card reader, card emulation ISO 14443 A / B, ISO 15693	
TEMPERATURE	Operating -20°C to 50°C Storage -30°C to 70°C	
HUMIDITY	0% to 95% non-condensing	
DROP TEST	1.2 m / 1.5m (with Boots)	
IP RATING	IP65	

Accessory

※ Content subject to change or added



Arm Band
(SL10, SL10K available)



Trigger Handle



Charging Cradle



M3 BK10 (BLACK)

The New Premier Mobile Computer

Windows CE 6.0 / Windows Embedded Handheld 6.5
1.0GHz CPU
1D Laser, 2D Imager
5.0MP Auto Focus Camera

Specification

PHYSICAL CHARACTERISTICS	
DIMENSION (W x H x D)	75.3 x 165.8 x 26 mm (2.96 x 6.52 x 1.02 in.)
WEIGHT	319 g
DISPLAY	VGA (480 x 640) QVGA (240 x 320)
BATTERY	Type Smart Battery
	Standard Li-Polymer 3.7 V 3,400mAh Extended Li-Polymer 3.7 V 5,100mAh
PERFORMANCE CHARACTERISTICS	
PROCESSOR	CPU 1GHz
OS	Windows Embedded Handheld 6.5
	Windows CE 6.0
MEMORY	RAM 512 MB
	ROM 8 GB
	Card Slot Micro SD
INTERFACE	USB 2.0 High Speed Host & Client
SENSORS	Light sensor, Gyro sensor
USER ENVIRONMENT	
TEMPERATURE	Operating -20 to 60°C / -4 to 140°F
HUMIDITY	Storing -30 to 80°C / -22 to 176°F
TUMBLE TEST	2,000 1.6 ft. / 0.5m tumbles (4,000 drops)
DROP TEST	5.9 ft. / 1.8 m
IP RATING	IP65

WIRELESS RADIO OPTIONS	
WWAN	2G GSM / GPRS / EDGE: Quad band (850 / 900 / 1800 / 1900 MHz)
	3.8G UMTS / HSPA+
WLAN	IEEE 802.11 a/b/g/n
SECURITY	WEP, WPA, WPA2, TKIP, AES, EAP-FAST, EAP-TLS, EAP-TTLS, PEAP-GTC, PEAP-TLS, PEAP-MMSCHAPv2, LEAP, CCXv4
BLUETOOTH	Class II, v2.1 with EDR
GPS	A-GPS, GLONASS
GENERAL OPTIONS	
SCANNER	1D Laser, 2D Imager
CAMERA	5.0 MP Auto Focus
KEYPAD	34 key Alpha Numeric
	53 Key QWERTY

Certifications



Pursuit of all-around excellence on a Mobile Computer, M3 Black

User-friendly design combined with high performance in harsh environments. The M3 BLACK has user-friendly design which is reliable and simple but very robust.

Key points



Ergonomic design can reduce fatigue during repetitive scanning

Low angle (23 °) barcode scanner
Low angle scanner allows users to feel more convenient during repetitive scanning operations in the field. The design provides convenience to users when looking at the LCD screen during scanning which reduces physical tiredness of wrists and eyes.



Continues to work even in darkness

5.0MP camera with ultra-flash

The 5.0MP ultra-flash helps users to use the camera even in the dark work condition. Data capturing and photographing in dark and harsh environments will be easily handled.



User-friendly design to locate the scan button by touch

Embossed scan buttons applied
Small bumps on the scan buttons on the front and side enables users to recognize and scan without looking which saves time and efficiency. Buttons are placed on an angle which makes it more easier to press.



Functional design withstands hard drop

Rubber / Metal applied on case
Many things can happen during working hours, such as dropping devices. By applying anti-slip rubber, the device will not slip from your hands. If you drop BK10, the metal frame can withstand multiple drops from at a maximum of 2 meters high.



M3 OX10-1G (ORANGE)

Top Rated Multi-Functional Handheld

1 GHz CPU
Windows CE 6.0 / Windows Embedded Handheld 6.5
HSPA+ / EDGE / GPRS / GSM
Integrated RFID Reader (HF / UHF)

Specification

PHYSICAL CHARACTERISTICS	
DIMENSION (W x H x D)	78.6 x 165.5 x 24.9 mm 78.6 x 165.5 x 40.2 mm (with HF reader) 78.6 x 165.5 x 38.9 mm (with UHF reader)
WEIGHT	332 g / 11.7 oz 362 g / 12.7 oz (with HF reader) 389 g / 13.7 oz (with UHF reader)
DISPLAY	VGA (480x640) QVGA (240x320)
BATTERY	Li-Ion 3.7 V 3,300 mAh, Smart Battery
SIM / SAM	1 SAM / 2 SAM (optional)
PERFORMANCE CHARACTERISTICS	
PROCESSOR	CPU 1 GHz
OS	Windows Embedded Handheld 6.5 Windows CE 6.0
MEMORY	RAM 512 GB ROM 4 GB Card Slot Micro SD
INTERFACE	USB Host 1.1 / Client 2.0
USER ENVIRONMENT	
TEMPERATURE	Operating -20 to 60°C / -4 to 122°F
HUMIDITY	Storing -30 to 70°C / -22 to 158°F
TUMBLE TEST	1,000 1.6 ft. / 0.5 m tumbles (2,000 drops)
DROP TEST	5.0 ft. / 1.5 m
IP RATING	IP65

WIRELESS RADIO OPTION	
WWAN	2G GSM / GPRS / EDGE: Quad band (850 / 900 / 1800 / 1900 MHz) 3.8G UMTS / HSPA+ : Five band (800 / 850 / AWS / 1900 / 2100 MHz)
WLAN	IEEE 802.11 a / b / g / n
SECURITY	WEP, WPA, WPA2, TKIP, AES, EAP-FAST, EAP-TLS, EAP-TTLS, PEAP-GTC, PEAP-TLS, PEAP-MSCHAPv2, LEAP, CCXv4
BLUETOOTH	Class II, V2.1 (With EDR)
RFID	HF ISO 14443 A / B, ISO 15693, ISO 18000-3, I-CODE) UHF EPC C1 G2
GPS	AGPS, GLONASS
GENERAL OPTIONS	
SCANNER	1D Laser, 2D Imager
CAMERA	5.0MP Auto Focus camera
KEYPAD	Alpha Numeric 31 Keys QWERTY 50keys (WM6.5 only)

Certifications



Key points



Rugged design for superior reliability

M3 OX10-1G is suitable to use in tough environments :
Withstands drop from 1.5m and resistant against dust and water.



Industry leading data capturing

1D, 2D, RFID (HF / UHF optional) options provide real-time data capture and automatic data processing enables flexibility in work and cost-efficiency.



Multi-function Keypads

Multi-functional keys of Qwerty keypads are designed for versatile performance.
Hot keys enable direct access and increase user's working speed.

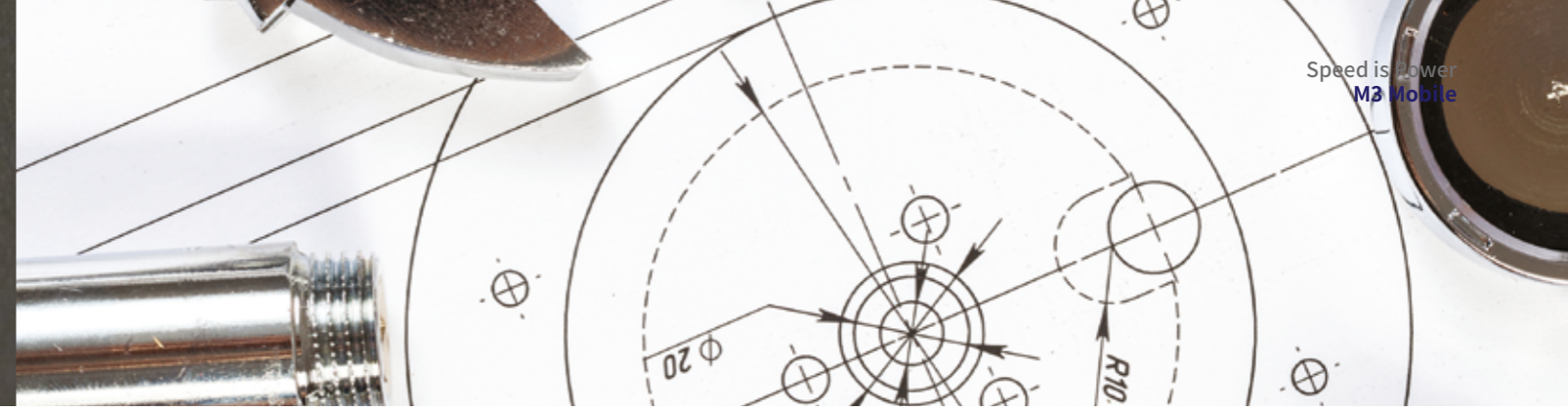

M3 Service Package

FOCUS ON SERVICE TYPE YOU NEED

Category		Standard Warranty (Extended)	Service Package	Service Package (Extended)
Term		1 Year (Optional 1 year extension)	3 Years or 5 Years	1 Year or 2 Years
Manufacture Defect		O	O	O
Wear and Tear		X	O	O
Repair cost due to defect		X	O	O
Turnaround	Time	5-7 Days	3 Days	3 Days
	Cost	One way (M3)	M3	M3
Accidental Breakage		X	O	O
Online Technical Support		O	O	O

O: Free Coverage

Note: Please check the latest information, including detailed contents and available service options.

CARRIAGE

Please send defective devices with printed Request Form (which has DOA# or RMA# indicated on the sheet) to below address:

Korea

M3 Mobile Headquarter Service center
Unit 604, 201 Chuni Technopark,
18 Buchen-ro 198 Beon-gil, Wonmi-gu,
Bucheon-si, Gyeonggi-do, 14557, Korea
Tel: +82-(0)2-574-0037
Email: peter.chae@m3mobile.co.kr
Attn: Peter Chae

All EU Countries Including Germany

JARLTECH Europe GmbH
Jarltech-Platz 1, 61250 Usingen Germany
Tel: +49-(0)-6081-600-303
Email: oliver.schulz@jarltech.de
Attn: Oliver Schulz

Germany

Weilandt Elektronik GmbH
Carolus-Magnus-Str.12, 45356 Essen Germany
Tel: +49-(0)-201-10-99-81-61
Email: t.perplies@weilandt-elektronik.de
Attn: Tobias Perplies

France

PRESTINFO MAINTENANCE
18, avenue de la ZAC de CHASSAGNES, TERNAY,
Lyon city, 69360, France
Tel: +33-(0)6-79-20-93-67
Email: Bertrand.Felix@prestinfo-maintenance.com
Attn: Bertrand Felix

UK

BIAS Technology Support LTD
7 Blackhill Road West, Holton Heath Trading Park,
Poole, Dorset, BH16 6LE, UK
Tel: +44-(0)-1202-620955
Email: gavind@biastechnology.com
Attn: Gavin Dalrymple